

WP 53 Safe TECHNICAL SHEET

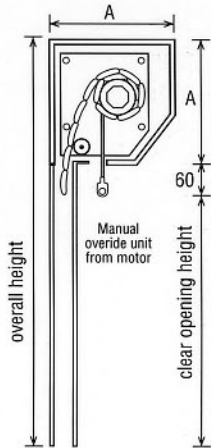

WP 53 Profile

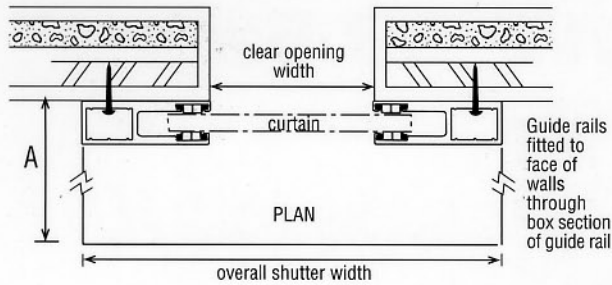
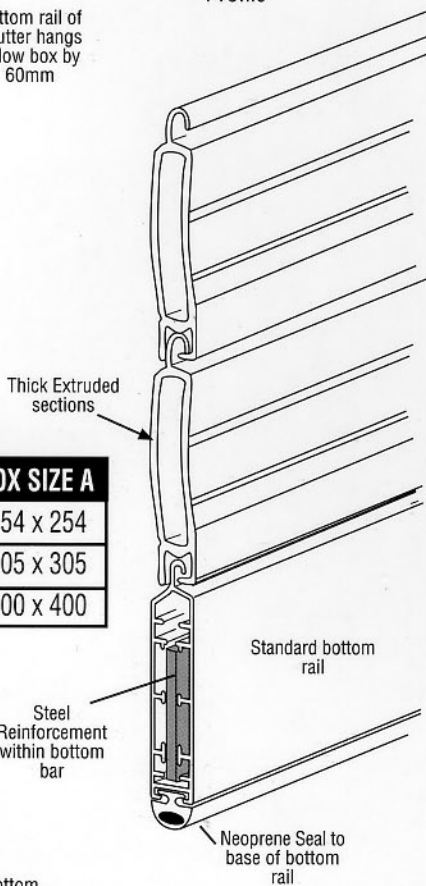

OVERALL HEIGHT	BOX SIZE A
up to 2350mm	254 x 254
up to 3650mm	305 x 305
up to 4500mm	400 x 400

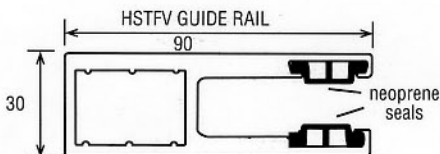
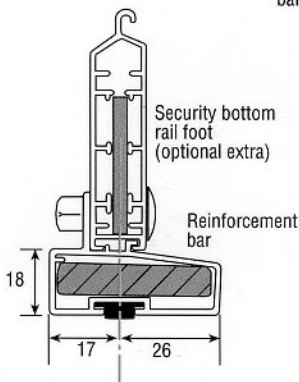

CURTAIN - 53mm x 14mm weight 12kg/m². Recommended usable size 5600mm x 2800mm. Constructed from double skinned extruded aluminium alloy 6036-T6, produced to BS1474 with special shaping for high security.

Curtains are available unvented only and in solid format. Each alternate profile is secured by a polyamide endlock which is inserted inside the profile and secured in place by rivets.

A double skinned extruded bottom rail complete with reinforcement bar is fitted to the base of the shutter as standard. As an optional extra a bottom rail security base section can be fitted with reinforced security steel bar inserted.

Curtain colours available are white or dark brown as standard with RAL/BS colours available at a surcharge.

BOX - GKSE 250/300/400 series.

Constructed from roll formed pre-stove enamelled aluminium sheet which is roll formed incorporating special folds to ensure rigidity and strength. Each box comes complete with a tough protective film for removal on completion. Standard box colours are white or dark brown. Other colours are available to suit any standard RAL/BS colour within our range at a surcharge.

BRACKETS (BOX ENDS) - GKSE 250/300/400 series.

Constructed from high-pressure moulded die cast aluminium or 3mm-6mm steel endplates in standard white or dark brown finish complete with deflection rollers. Other colours are available to suit any standard RAL/BS colour at a surcharge. On larger doors a sliding bracket system is used to reduce deflection. Contact our technical department for further details.

GUIDE RAILS - HSTFV SAFE 90 x 30 x 5

Constructed from extruded aluminium alloy 6036-T6 produced to BS1474 incorporating neoprene seals to ensure no metal to metal contact and to ensure smooth and quiet operation. Standard colours available are white or dark brown with other colours available to suit any standard RAL/BS colour within our range at a surcharge.

OPERATION - Due to the weight of this door normal operation is by tubular Somfy electric motor with rapid set limits and a thermal overload facility fitted as standard. Switching is by internal rocker switch or external keyswitch. Remote control units are available with rolling code and funnel reception range at a surcharge. A manual override facility, for emergency operation in the event of a power failure, is also available at a surcharge.

For further information please call our Technical Department .